

Innovative GET System of SBIC

QLOK

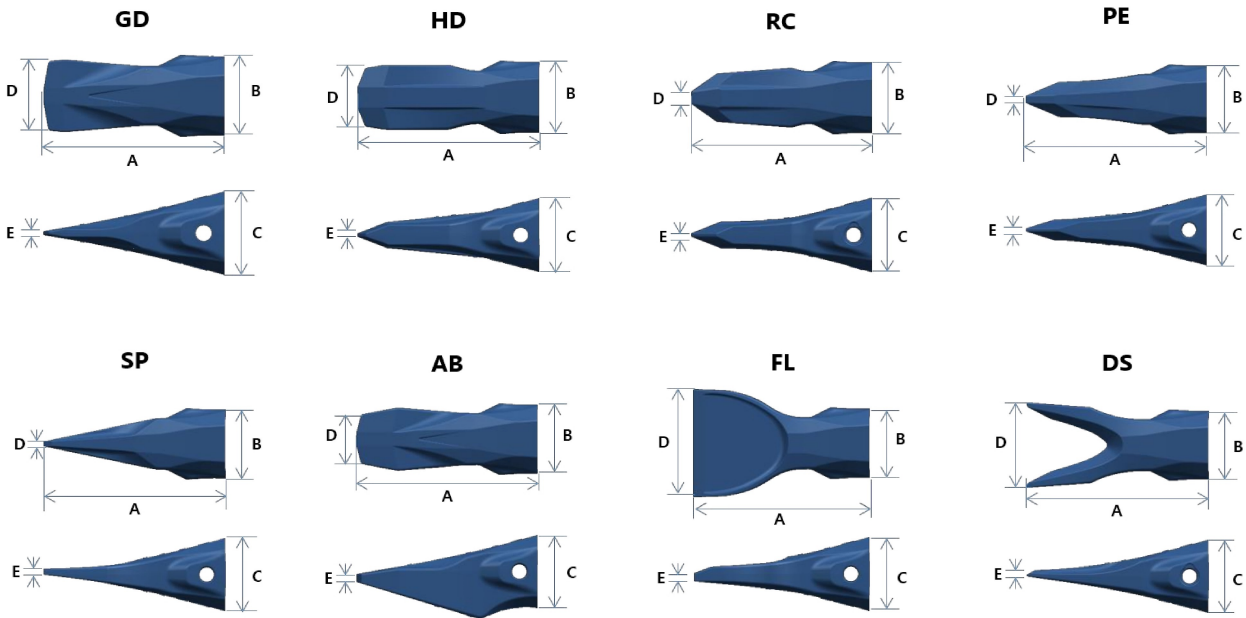



SBM30 Tooth

Part No.	Description	A	B	C	D	E	Weight (kg)	Remark
		mm	mm	mm	mm	mm		
SBM30GD	GD, General Duty	590	250	250	225	12	78.5	-
SBM30SP	SP, Spike	595	250	253	36	15	67.5	-
SBM30HD	HD, Heavy Duty	590	250	250	225	45	92.5	-
SBM30RC	RC. Rock Chisel	540	250	250	69	15	65	-
SBM30RCS	RCS. Rock Chisel Short	500	250	250	59	15	59	-
SBM30HDI	HDI, Heavy Duty Impact	490	250	257	110	45	85	-

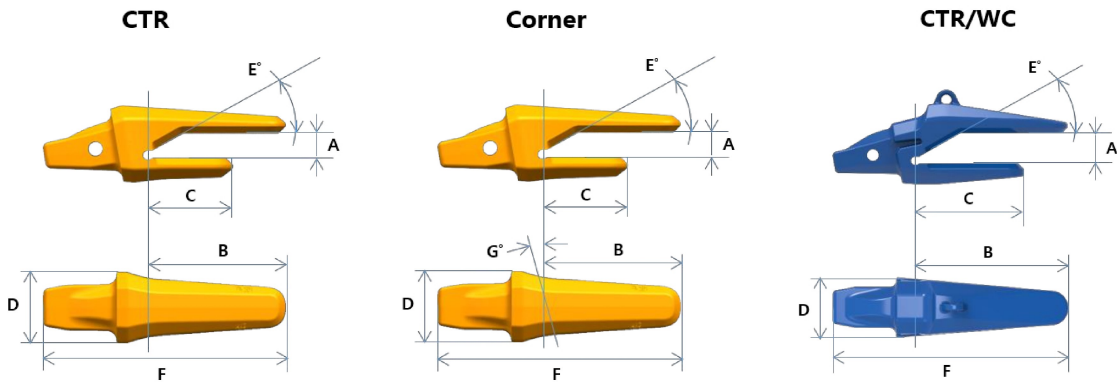

SBC07 Adapter

Part No.	Description	A	B	C	D	E	F	G	Weight (kg)	Remark
		mm	mm	mm	mm	°	mm	°		
SBC071170	Standard CE	70	416	270	195	30	637	-	62	-
SBC071180	Standard CE	80	416	270	195	30	637	-	60.65	-
SBC071190	Standard CE	90	358	213	195	30	637	-	58.9	-
SBC071170WC	WC AD	70	410	255	195	30	643	-	63.7	-
SBC071180WC	WC AD	80	410	255	195	30	643	-	62.3	-
SBC071190WC	WC AD	90	410	255	195	30	643	-	60.7	-

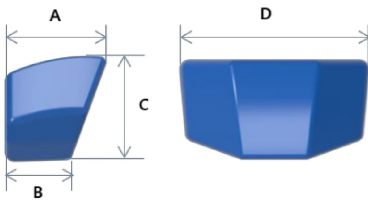

Part No.	Description	A	B	C	D	Weight (kg)
		mm	mm	mm	mm	
SBC07WC	Wear Cap	120	62	90	188	5.3
SBM15WC	Wear Cap	127	54	110	186	6.7
SBM20WC	Wear Cap	147	119	72	210	10.4
SBM25WC	Wear Cap	180	90	125	259	14.9
SBM30WC	Wear Cap	170	135	86	240	15.0
SBM35WC	Wear Cap	200	100	130	289	18.5

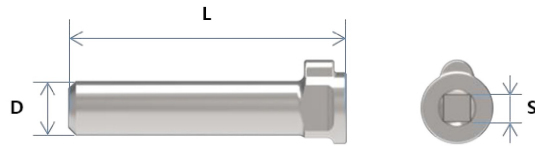

Locking Pin

Part No.	Description	L	D	S (Socket)		Weight (kg)	Remark
		mm	mm	mm	inch		
SBQP01	Locking Pin	85	16	9	5/16	0.11	
SBQP02	Locking Pin	106	22	11	3/8	0.34	
SBQP03	Locking Pin	112	22	11	3/8	0.35	
SBQP04	Locking Pin	138	25	14	1/2	0.56	
SBQP05	Locking Pin	157	29	14	1/2	0.85	
SBQP07	Locking Pin	175	33	14	1/2	1.2	
SBQP15	Locking Pin	185	33	21	13/16	1.3	
SBQP20	Locking Pin	209	37	21	13/16	1.8	
SBQP25	Locking Pin	240	40	21	13/16	2.1	
SBQP30	Locking Pin	221	40	21	13/16	2.3	
SBQP35	Locking Pin	270	40	21	13/16	2.7	